

stamixco



Static Mixing Systems

At your service

stamixco



Stamixco designs and manufactures a wide variety of static mixers (motionless mixers with no moving parts) for the continuous processing of polymers, liquids, gases and slurries. Our customers utilize our technology to solve operating issues relating to mixing, dispersion, reaction, heat transfer and the conditioning of fluid flow. In front of low pressure drop process equipment and instrumentation. Stamixco views ourselves as a competent partner with our customers so they can realize their process improvement needs. Our many years of experience, know-how and on-going research & development activities have

made us a technology leader in our industry where we are owner-operated and internationally established. Our dual headquarter locations in Winterthur, Switzerland and New York, U.S.A. are staffed with highly competent engineers which assures local competency and service. In addition, we have sales representative and distributors in most major countries of the world. In summary, we continuously endeavour to design and supply solutions to our customer's needs which has resulted in many patented and proprietary products.

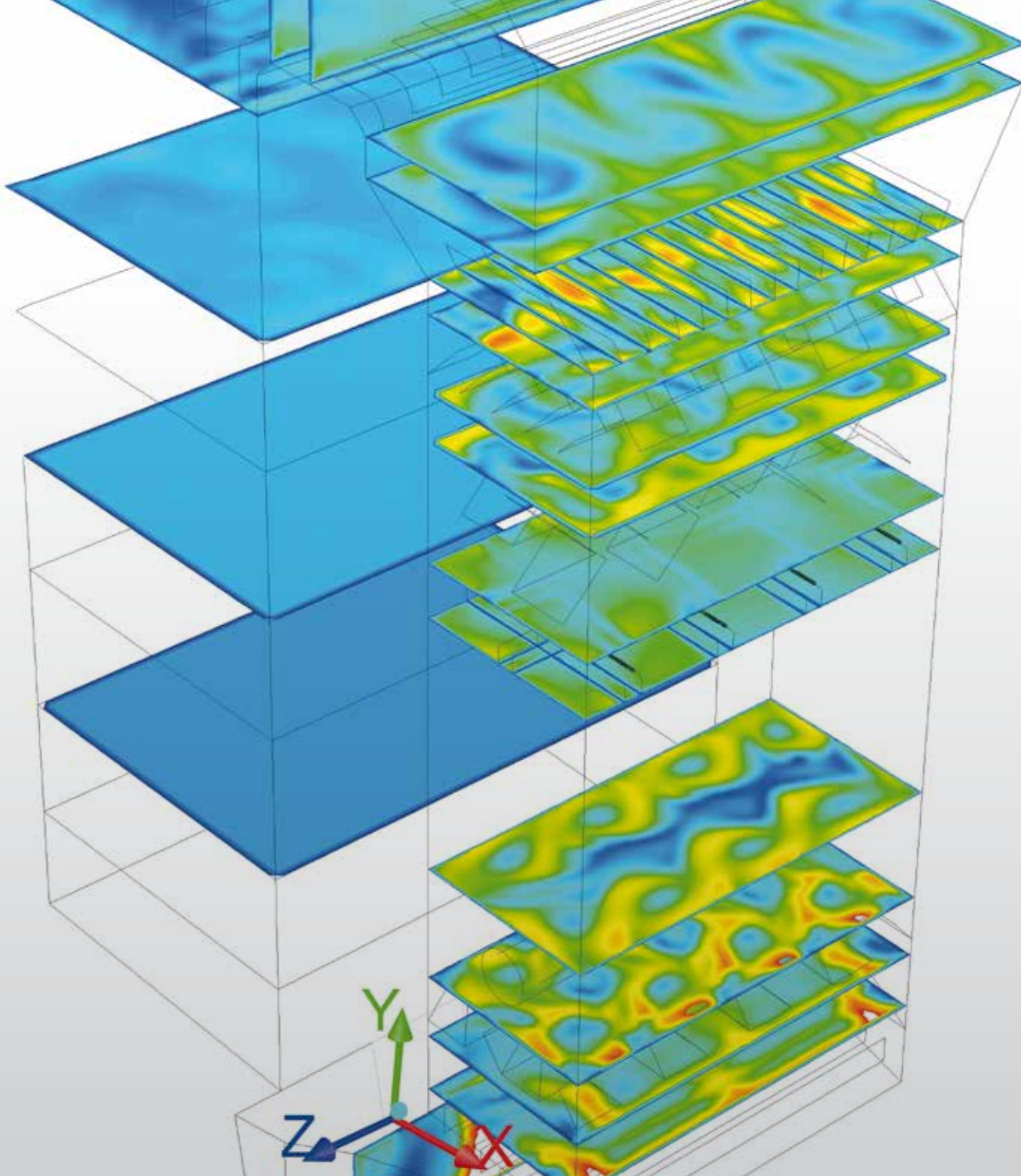

Stamixco designs and manufactures a wide variety of static mixers (motionless mixers with no moving parts) for the continuous processing of polymers, liquids, gases and slurries. Stamixco views ourselves as a competent partner with our customers so they can realize their process improvement needs. Our many years of experience, know-how and on-going research & development activities have made us a technology leader in our industry where we are owner-operated and internationally established. In addition, we have sales representative and distributors in most major countries of the world. In summary, we continuously endeavour to design and supply solutions to our customer's needs which has resulted in many patented and proprietary products.

**Flow Engineering Computational Fluid Dynamics (CFD):**

This allows Flowtech and Stamixco to perform advanced 3-dimensional simulations of very complex flow conditions and optimize existing products and installations.

**Flow Optimization via Physical Flow Models:**

In some instances, digital flow simulations are inadequate for achieving the most economical solution. In these instances, Flowtech designs and builds experimental flow models in 1:10 - 1:12 scale. These scale models are then operated with highly experienced pilot plant personnel and sophisticated measuring instrumentation to verify performance for scale-up.

**Equipment Components:**

To optimize solutions to customers processing issues, Flowtech, in conjunction with Stamixco, design, test and fabricate key components such as static mixers, inlet nozzles and distributors, flow straightening components, control equipment and housings.



## Injection Moulding

Injection Moulders' must deal with many different moulding tools, polymer types and formulations and colour additives and master batches. Production rate, yield and high quality products are key to their success. The probability of success is greatly increased by installing an SMN static mixer injection moulding mixing nozzle direct upstream the moulding-tool.

The Stamixco patented SMN mixing element geometry achieves excellent mixing results in a very short length. The high performance mixing elements homogenize the polymer melt during the injection process directly upstream of the mould. This homogenization is achieved by the con-

tinual division and recombination of the molten polymer as it passes through the geometric structure of the mixing elements. As a result, all additives and colorants and temperature and viscosity gradients created by the screw are mixed and evenly distributed just before entering the mould. The SMN Mixing Elements are extremely strong due to their monolithic cast construction where the mixing bars are joined to each other and to the external ring wall via a single molten metal pour.

Auxiliary components that can be mounted inside the SMN Mixing Nozzle housing include Filters and Cold-Start Grid Protection devices. All mixing elements and auxiliary components are standard and can be individually added or removed from the mixing nozzle as required.

# Static Mixers for Injection moulding

## BENEFITS

- Reduced spots, streaks and clouds of colour
- Reduced colorant usage (up to 30% less)
- Narrower part tolerance of final parts
- Reduced reject rates
- Less part distortion
- Less part weight variation
- Improved part quality when using regrind material and increased use of regrind.
- Shorter cycle times
- Improved surface and mechanical properties
- Blended thermal degradation products (i.e., PET)
- Improved melt flow, uniform filling of multi-cavity moulds
- Expanded operating range of older machines



SMN-Mixing Nozzle with heater band and temperature Sensor

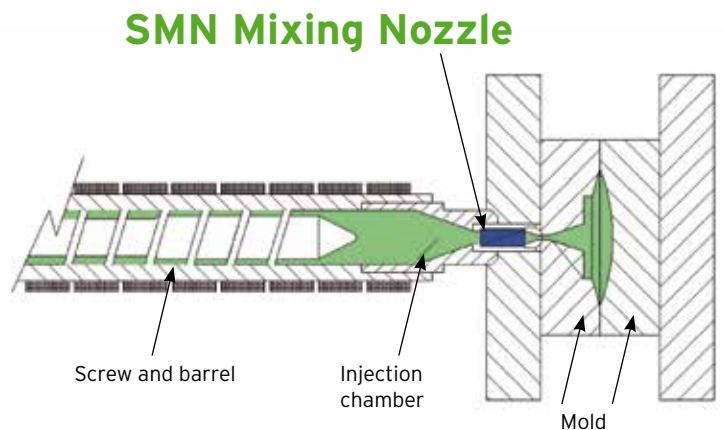

## SMN Standard Mixing-Set with 8 Mixing Elements (ME)

Diameter	I.D. <sub>ME</sub> (mm)	O.D. <sub>ME</sub> (mm)	L (ME) (mm)	L (Total) (mm)	Weight (kg)
<b>SMN-12-8</b>	12	18	8	64	0,07
<b>SMN-18-8</b>	18	26	11,25	90	0,2
<b>SMN-22-8</b>	22	30	13,5	108	0,31
<b>SMN-27-8</b>	27	35	16,5	132	0,45
<b>SMN-33-8</b>	33	42	20	160	0,82
<b>SMN-40-8</b>	40	50	24	192	1,26
<b>SMN-52S-8</b>	52	62	31,5	252	2,45

## SMN Mixing-Set with 7 Mixing Elements (ME) and 1 Grid-Protection-Device (GPD)

Diameter	I.D. <sub>ME</sub> (mm)	O.D. <sub>ME</sub> (mm)	L (ME) (mm)	L (Total) (mm)	Weight (kg)
<b>SMN-18-7+1 GPD</b>	18	26	11,25	90	0,21
<b>SMN-22-7+1 GPD</b>	22	30	13,5	108	0,32
<b>SMN-27-7+1 GPD</b>	27	35	16,5	132	0,47

## SMN Mixing-Set with 6 Mixing Elements (ME) and 1 Filter (SMF)

Diameter	I.D. <sub>ME</sub> (mm)	O.D. <sub>ME</sub> (mm)	L (ME) (mm)	L (Total) (mm)	Weight (kg)
<b>SMN-12-6+1 SMF</b>	12	18	8	64	0,07
<b>SMN-18-6+1 SMF</b>	18	26	11,25	90	0,21
<b>SMN-22-6+1 SMF</b>	22	30	13,5	108	0,32
<b>SMN-27-6+1 SMF</b>	27	35	16,5	132	0,49
<b>SMN-33-6+1 SMF</b>	33	42	20	160	0,90
<b>SMN-40-6+1 SMF</b>	40	50	24	192	1,41

## Grid-Protection-Device (GPD)

Diameter	I.D. (mm)	O.D. (mm)	L (GPD) (mm)	Fits to:	Weight (kg)
<b>GPD-18</b>	18	26	11,25	SMN-18	0,03
<b>GPD-22</b>	22	30	13,5	SMN-22	0,05
<b>GPD-27</b>	27	35	16,5	SMN-27	0,08

## Filter (SMF)

Diameter	I.D. (mm)	O.D. (mm)	L (SMF) (mm)	Fits to:	Weight (kg)
<b>SMF-12</b>	12	18	16	SMN-12	0,02
<b>SMF-18</b>	18	26	22,5	SMN-18	0,06
<b>SMF-22</b>	22	30	27	SMN-22	0,09
<b>SMF-27</b>	27	35	33	SMN-27	0,15
<b>SMF-33</b>	33	42	40	SMN-33	0,28
<b>SMF-40</b>	40	50	48	SMN-40	0,46

### Choice of SMN Mixing Element Size:

Seven (7) standard mixing element assembly sizes are available that cover the operating range of very small to very large commercial injection molding machines. The size of mixing nozzle to be installed depends on the polymer volumetric flow rate and viscosity of the melt. To perform accurate design calculations, polymer melt rheology information is required (shear rate vs. viscosity at operating conditions and MFI).

### SMF-Filter:

- Protects the mixing elements, nozzle tip, hot runner system and tooling from clogging and damage when processing regrind material by filtering unwanted solids (e.g. aluminium metal parts, pebbles, staples, etc.) in the polymer melt that a magnetic separator does not catch.
- Holds back partially melted pellets until melted.

### GPD Grid-Protection-Device:

- Protects the SMN static mixing elements from possible damage due to a "Cold Start" event when a slug of unmelted polymer under high pressure strikes the face of the mixing elements and damages them. The GPD is extremely strong and prevents unmelted polymer from striking the mixing elements.

**SMN Mixing-Set with 8 ME**



**SMN Mixing-Set with 7 ME and 1 GPD**



**SMN Mixing-Set with 6 ME and 1 SMF**

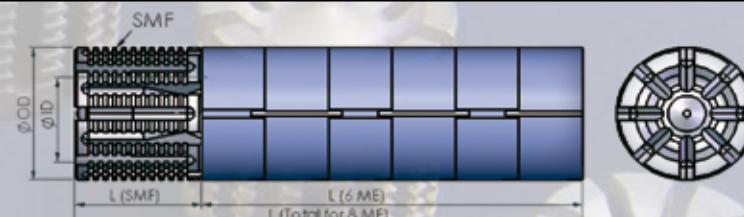

**GPD**



**SMF**

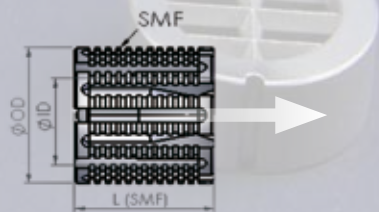

The SMN Mixing Nozzle consists of a mixing nozzle housing that holds the standard eight (8) SMN mixing elements (licensee of Bayer AG, Germany). The inlet side threaded adaptor connects to the injection moulding machine. The outlet side adaptor with nozzle tip connects to the mould. The entire mixing nozzle is heated by heater bands whose temperature is controlled by a thermocouple. Mixing Element assemblies only or complete Ready-to-Run Mixing Nozzles are available.



Sectional model of a SMN Mixing Nozzle

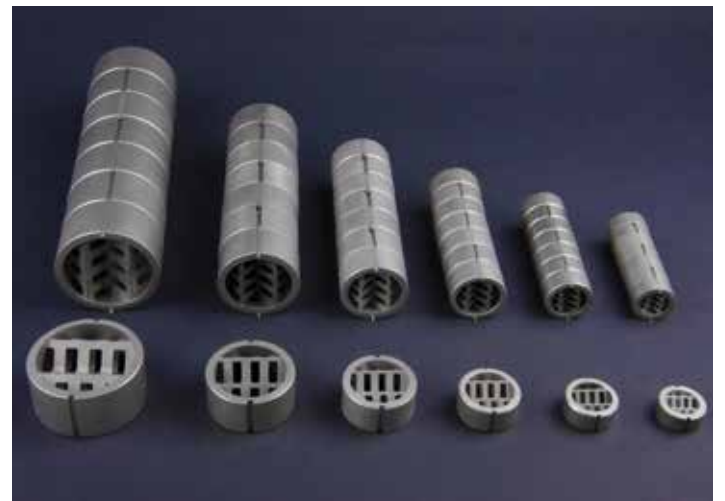

Model range of standard SMN Mixer-Sets

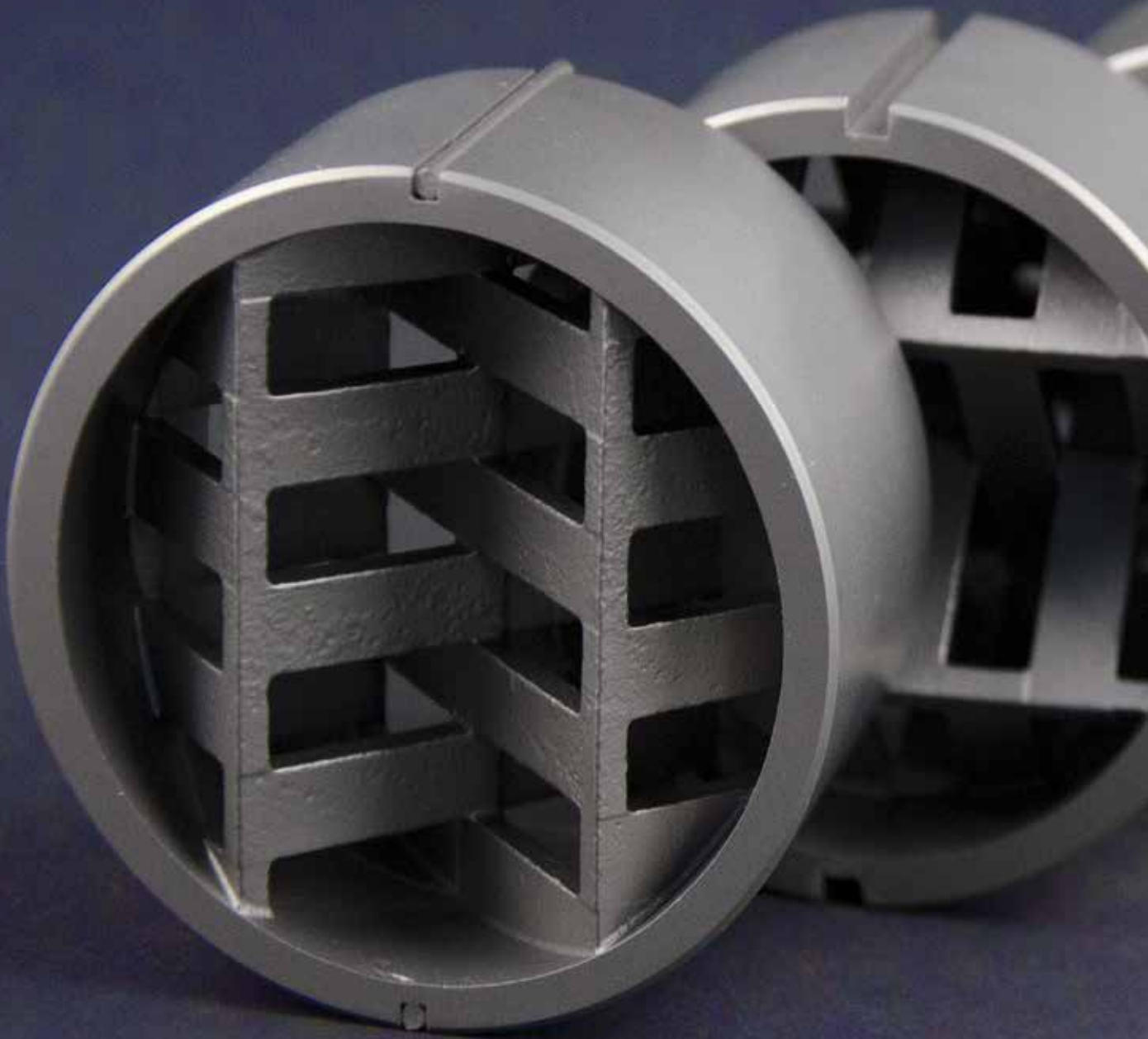

Static Mixers for Extrusion applications are often called "Melt Blenders". They are installed directly upstream of the die. They homogenize the polymer melt just before forming the end product in the die. Differences in temperature and concentration of colorants and additives are equalized. By this mixing process, polymer melt viscosity differences are reduced to a minimum and thus the polymer flow behavior is optimized. At the same time, colorant spots and streaks are eliminated. This homogenization is achieved by the continuous division and recombination of the molten polymer when pushed through the geometric structure of the mixing elements

#### **Applications:**

- **Sheet**
- **Blown Film**
- **Foam sheet**
- **Profile extrusion**
- **Co-extrusion**
- **Pipe**
- **Extrusion Blow Molding**
- **Rod & Tubing**
- **Wire & Cable**
- **Coatings**
- **Fiber extrusion & monofilaments**



# Static Mixers for Extrusion

## BENEFITS

- Homogenous melt with equal distribution of temperature and viscosity
- Reduced colorant and additive usage
- Streak free product
- Improved admixing of regrind material
- Uniform melt flow in the die reduces time needed for die adjustment
- Improves foam cell size and cell distribution uniformity in foamed products
- Improved surface quality and mechanical characteristics
- Less wastage
- Stabilizes the entire extrusion process



Melt Blender Set SMB-R

## SMB Melt Blender

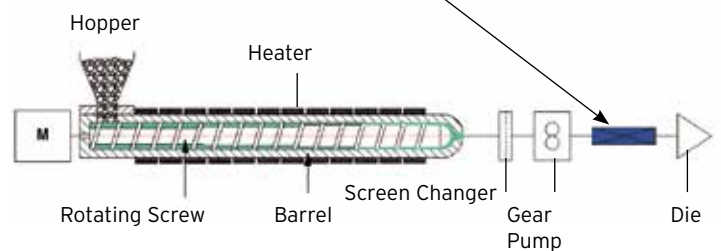

## SMB-R Melt Blender Set with 8 Mixing Elements

Special Cast with 8 rings

Diameter	I.D. <sub>ME</sub> (mm)	O.D. <sub>ME</sub> (mm)	L <sub>ME</sub> (mm)	-	L (Total) mm	Weight (kg)
<b>SMB-R-25-8</b>	20	25	12,5	-	100	0,17
<b>SMB-R-32-8</b>	27	32	16	-	128	0,3
<b>SMB-R-48-8</b>	40	48	24	-	192	1,1
<b>SMB-R-60-8</b>	52	60	30	-	240	1,75
<b>SMB-R-75-8</b>	66	75	37,5	-	300	3,25
<b>SMB-R-90-8</b>	80	90	45	-	360	4,85
<b>SMB-R-115-8</b>	102	115	57,5	-	460	10,4
<b>SMB-R-140-8</b>	126	140	70	-	560	16,3
<b>SMB-R-175-8</b>	154	175	90	-	720	42,5
<b>SMB-R-200-8</b>	175	200	102,5	-	820	64
<b>SMB-R-225-8</b>	200	225	115	-	920	85
<b>SMB-R-250-8</b>	225	250	130	-	1040	110

## SMB-GXS-8 Melt Blender Rod with 8 Mixing Elements

Special Cast with integrated stiffeners

Diameter	D (Bore) (mm)	D (Mixer) (mm)	Da (Ring) (mm)	L (Ring) (mm)	L (Total) mm	Weight (kg)
<b>25/32 - 8</b>	25	24,7	32,0	20	138	0,16
<b>40/48 - 8</b>	41,5	40,6	48,0	30	211	0,45
<b>50/60 - 8</b>	52	50,7	60,0	35	268	0,8
<b>65/75 - 8</b>	68	66,5	75,0	42	351	1,6
<b>80/90 - 8</b>	82	80	90,0	53	435	2,8
<b>100/115 - 8</b>	103,5	101,2	115,0	63	528	5,4
<b>125/140 - 8</b>	129,5	126,2	140,0	68	684	10,5

## SMB-GXS-4 Melt Blender Rod with 4 Mixing Elements

Special Cast with integrated stiffeners

Diameter	D (Bore) (mm)	D (Mixer) (mm)	Da (Ring) (mm)	L (Ring) (mm)	L (Total) mm	Weight (kg)
<b>25/32 - 4</b>	25	24,7	32,0	20	75	0,1
<b>40/48 - 4</b>	42	40,6	48,0	30	115	0,3
<b>50/60 - 4</b>	52	50,7	60,0	35	144	0,6
<b>65/75 - 4</b>	68	66,5	75,0	42	190	0,9
<b>80/90 - 4</b>	82	80	90,0	53	230	1,8
<b>100/115 - 4</b>	103,5	101,2	115,0	63	282	3,8
<b>125/140 - 4</b>	129,5	126,2	140,0	68	348	6,0

## SMB-GX-4 Melt Blender Rod with 4 GXM Mixing Elements

Welded in stainless steel

Diameter	D (Bore) (mm)	D (Mixer) (mm)	Da (Ring) (mm)	L (Ring) (mm)	L (Total) mm	Weight (kg)
<b>48</b>	42	41,3	48,0	30	auf Anfrage	auf Anfrage
<b>60</b>	52	51,8	60,0	35	auf Anfrage	auf Anfrage
<b>75</b>	68	66,5	75,0	42	auf Anfrage	auf Anfrage
<b>90</b>	82	80,2	90,0	53	auf Anfrage	auf Anfrage
<b>115</b>	103,5	101,5	115,0	63	auf Anfrage	auf Anfrage
<b>140</b>	129,5	126,2	140,0	68	auf Anfrage	auf Anfrage
<b>175</b>	155	153,5	175,0	-	auf Anfrage	auf Anfrage
<b>DN 200 - 400</b>	-	-	-	-	auf Anfrage	auf Anfrage

## SMB-H Melt Blender Rod with 6-9 Mixing Elements

Machined in stainless steel

Diameter	D (Bore) (mm)	D (Mixer) (mm)	Da (Ring) (mm)	L (Ring) (mm)	L (Total) mm	Weight (kg)
<b>16 - 125</b>	on request	on request	on request	on request	on request	-

## Helical Mixing Elements L/D= 1.5 or L/D= 1.0

### Mixing Quality

The optimum melt polymer quality for extrusion installations is when at each location inside the polymer melt volume a uniform distribution of colorant, additives and melt temperature is measured. Using the Stamixco SMB Melt Blender with 8 mixing elements assures that the homogeneity of the melt is improved by a factor 5-6 or more. Pay-back time of Melt Blender installations are short and often less than 2-4 months.

The SMB-R mixing elements are extremely strong due to their monolithic cast construction where the mixing bars are joined to each other and to the external ring wall via a single molten metal pour. The size of the melt blender is a function of flow rate and viscosity of the polymer melt. To perform accurate design calculations, the polymer rheology is required (shear rate vs. viscosity at operating conditions and MFI).

## Melt Blender SMB-R

Bayer Licence



## Melt Blender SMB-GXS-8

Stamixco Patent



## Melt Blender SMB-GXS-4

Stamixco Patent

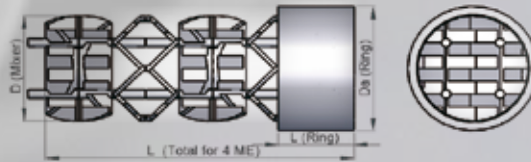

## Melt Blender SMB-GX-4



## Melt Blender SMB-H

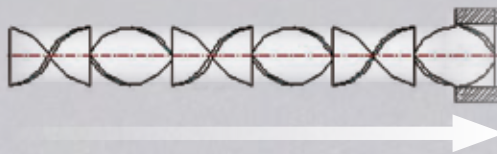

SMB-GXS Melt Blenders as casted unit with integrated stiffeners (middle and right) in comparison with welded SMB-GX Melt Blender (left)



SMB-H Melt Blender

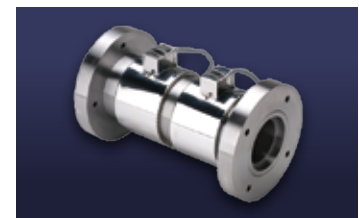

Melt Blender Housing with heater bands and sensors



Stamixco has a wide variety of High Performance plastic disposable static mixers that are ideally suited for difficult mixing applications and when mixing in a short length is critical. Difficult mixing applications include those where the materials to be mixed have large differences in volumetric ratio and/or viscosity ratio and where a very high degree of mixing is required.

# Plastic Disposable Static Mixers

## BENEFITS

- The X-Grid plastic disposable static mixers are the only High-Performance designs in the marketplace.
- Flexible number of mixing elements
- High Performance X-Grid static mixers can provide the identical mixing of the industry standard helical static mixer in a much shorter length. In addition, they can mix materials that are impossible to mix with helical static mixers.
- Smaller Mixer Volume: Reduces product waste

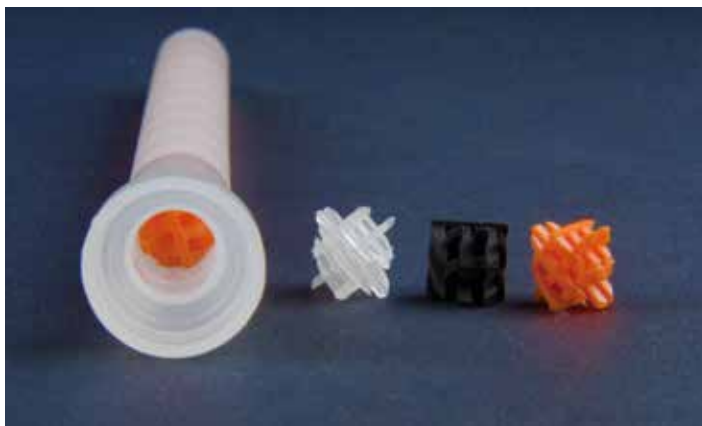

Stamixco X-Grid Mixer GXP as disposable mixer

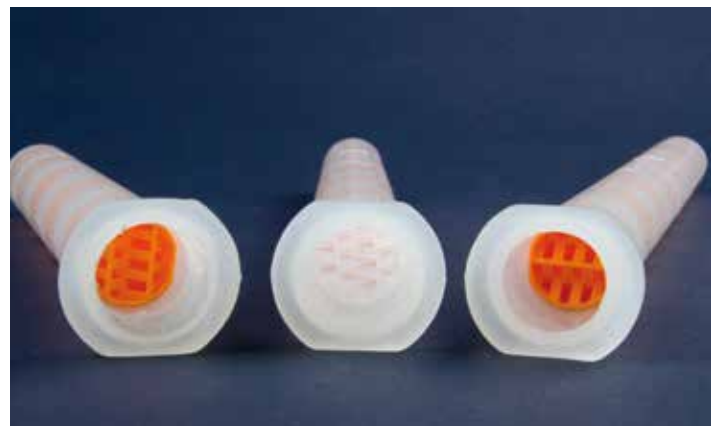

Inside view of Stamixco GFX-21 disposable mixer

## X-Grid Disposable Mixer GXF-10

	Material Mixer	Color	Diameter Mixing Elements (mm)	Number of Mixing Elements	Length Pipe (mm)
<b>GXF-10-6 (Mixing Pipe)</b>	Polypropylen	orange	ME-Inside- Diameter = 10	6	115
<b>GXF-10-9 (Mixing Pipe)</b>	Polypropylen	orange		9	155
<b>GXF-10-12 (Mixing Pipe)</b>	Polypropylen	orange	ME-Outside- Diameter = 11.8	12	192
<b>GXF-10 (ME only)*</b>	Polypropylen	orange		8 Rings = 2 ME	13,7

## X-Grid Disposable Mixer GXF-21

	Material Mixer	Color	Diameter Mixing Elements (mm)	Number of Mixing Elements	Length Pipe (mm)
<b>GXF-21-9 (Mixing Pipe)</b>	Polypropylen	orange/white	ME-Innen- durchmesser = 21	9	305
<b>GXF-21-12 (Mixing Pipe)</b>	Polypropylen	orange/white		12	385
<b>GXF-21-15 (Mixing Pipe)</b>	Polypropylen	orange/white	ME-Aussen- durchmesser = 23.8	15	465
<b>GXF-21 (ME only)*</b>	Polypropylen	orange/white		4 Ringe = 1 ME	26,7

## X-Grid Disposable Mixer GXP

	Material Mixer	Color	Diameter Mixing Elements (mm)	Number of Mixing Elements	Length Pipe (mm)
<b>GXP-9.4-20 (Mixing Pipe)</b>	Polypropylen	orange/white	9,4	20	232
<b>GXP (ME only)*</b>	Polypropylen	orange/white	9,4	1	9,4
<b>GXP (ME only)*</b>	PA66 Glass fibers	black	9,4	1	9,4

## X-Grid Disposable Mixer GXR

	Material Mixer	Color	Diameter Mixing Elements (mm)	Number of Mixing Elements	Length Pipe (mm)
<b>GXR (ME only)*</b>	PA66 Glass fibers	black	Inside Diameter = 21 Outside Diameter = 29.7	4 Rings = 1 ME	13,2

## Helical Disposable Mixer

	Material Mixer	Color	Diameter Mixing Elements (mm)	Number of Mixing Elements	Length Pipe (mm)
<b>HAT-10-4.8-8,16,24,32,48</b>	Mixing Elements: POM, Acetal	white	4,8	8, 16, 24, 32 o. 48	68 bis 231
<b>HAT-10-6.3-8,16,24,32,48</b>		white	6,3	8, 16, 24, 32 o. 48	91 bis 336
<b>HAT-10-8.0-18,24,32</b>		white	8	18, 24 o. 32	179 bis 293
<b>HAT-10-9.3-12,18,24,30,40,60,64</b>	Pipe: Polypropylen	white	9,3	12, 18, 24, 30, 40, 60 o. 64	141 bis 611
<b>HAT-10-12.7-12,18,24,30,36</b>		white	12,7	12, 18, 24, 30 o. 36	172 bis 424
<b>Big-Helicals 34.7-4 (ME only)*</b>	ME: Polypropylen	white/orange	34.7	4 er Stangen	110

\* ME = Mixing Elements only without Mixing Pipe

Helical Plastic Disposable Static Mixers are not always able to create acceptable mixing results. Stamixco High Performance X-Grid plastic disposable static mixers deliver much better mixing results in a short length and with lower mixer volumes. Comparing the Medium Performance Helical static mixer to the High Performance X-Grid static mixer, the X-Grid static mixer provides up to 60% shorter mixing length and volume to reach the same mixing quality.

Stamixco offers a wide range of High Performance X-Grid static mixers made in various plastics for solving most difficult mixing applications. Mixing applications that cannot be solved with Medium Performance Helical mixers can be solved with High Performance X-Grid static mixer Models GXF, GXP or GXR.

## GXF-10



The Stamixco patented GXF plastic disposable static mixer is available in 10 mm diameter plastic housings with 6, 9 and 12 mixing elements. These foldable mixing elements can also be installed inside of metal pipe and tubing with inside diameter of 12 mm. They are used for processing small flow rates in difficult meter-mix-dispense applications such as adhesives, varnishes, urethanes, sealants and liquid silicone rubber (LSR), etc.

## GXF-21



The Stamixco patented GXF-21 plastic disposable static mixer is available in a large diameter of 21 mm in a plastic housing with 9, 12, and 15 mixing elements. These large diameter units can be connected with standard bell connections, flanges, 3/4» NPT threaded connections at the inlet and 1/2» NPT threaded connections at the outlet.

## GXP



The GXP plastic disposable static mixer is available in a 9.4 mm diameter in 50% glass filled Nylon PA66 and Polypropylene construction. The GXP is used for difficult meter-mix-dispense applications. Standard plastic housings are available with 20 mixing elements. Also available are special high pressure plastic housings that hold 6 mixing elements with a maximum operating pressure of 100 bar. These plastic housings can be connected in series via ring fittings M18 X1.5 mm.

## GXR-P



The Stamixco patented GXR-P plastic static mixing elements have support rings around the mixing element structure and are available in a 29.7 mm outside diameter and 21 mm inside diameter in 50% glass filled Nylon PA66 material. They are used for high pressure and temperature applications and are normally installed inside of high pressure metal tubing.. As with all High Performance X-Grid static mixers, they are used for processing difficult mixing applications where the materials to be mixed have large differences in volumetric and viscosity ratios as in many liquid silicone rubber (LSR) applications.

## Helical



The Helical static mixer is the industrial standard mixing geometry for plastic disposable applications. The Helical mixer is available in a very wide range of diameters, number of mixing elements (ME) and configurations. Standard materials of construction are Acetal (POM) for the mixing elements and Polypropylene for the housing. The Helical static mixer is best suited for easy to moderate difficulty mixing applications. It is also available in large diameters up to 34.7 mm.



Stamixco foldable GXF X-Grid Mixing Elements



Top: Stamixco Special Helical made in PTFE  
Center: Helical Mixer rod with diameter 24 mm made in POM  
Bottom: Big size Helical Mixer rod with diameter 34.7 mm made in PP.



Based on our many years of experience in designing and fabricating static mixers, Stamixco static mixers are used in a wide variety of applications. Depending on parameters such as volumetric and viscosity ratios, density and concentration of the materials to be mixed, the ideal mixing geometry is selected. Issues to consider include: are the fluids

soluble in each other or do they need to be dispersed?; are the gases to be processed soluble in the liquid processed and in what ratios? Examples are turbulent gas mixing for flue gas cleaning units or ozonisation in water treatment plants. The experience of Stamixco guarantees the best solutions in both laminar and turbulent flow applications.



# General Mixing

## BENEFITS

- **Controlled, equal mixing over entire cross section**
- **Low Energy input (only pressure drop over mixer length)**
- **No moving parts**
- **Continuous processing operations**
- **Clearly specified shear- and turbulence areas**
- **Short residence time distribution (plug flow)**



Stamixco Stainless Steel Helical Mixers  
in various diameters



Stamixco Stainless Steel GXM X-Grid  
Mixer rods down to 10 mm diameter

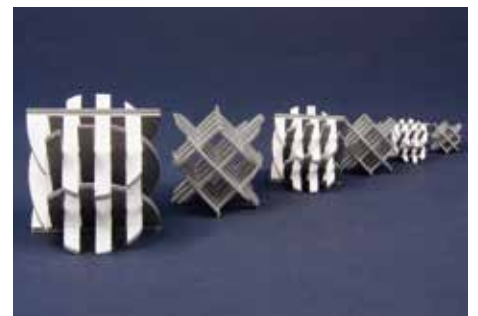

Selection of Stamixco standard GXM-  
X-Grid Mixing Elements

## Stamixco Experience in Static Mixing Technology

Static Mixers are efficient, accurate and powerful tools when used in continuous processes where they homogenize fluids with no moving parts. Pumps or blowers are used to deliver the components to be mixed at the desired volumetric flow rates and to also supply the pressure energy required for mixing.

Based on the specific application, different static mixer designs and housings are possible. Typical end connections are flanges, threaded ends, compression rings, welding ends, etc. The Mixing elements can be welded to the housing inside diameter or can be removable. Various metal and plastic materials are used.

### Comparison of laminar mixing performance with colored epoxy resins over same mixing length

Empty Pipe

Helical Mixer

X-Grid Mixer GXM



#### Picture left: Empty Pipe

Flow profile of laminar flow through empty pipe. It is clear visible that there is no mixing effect. Along the pipe wall an increasing dead-area is forming. This dead-area is colored in blue.

#### Picture middle: Static Helical Mixer

Laminar layer building and doubling of layers by each mixing element. Low mixing effect over given mixing length. Longer mixing length required.

#### Picture right: Static X-Grid Mixer GXM

Laminar layer building of each 8 multiplied layers per mixing element. Excellent mixing effect by shortest mixing length.

**Mixer for ozonisation**

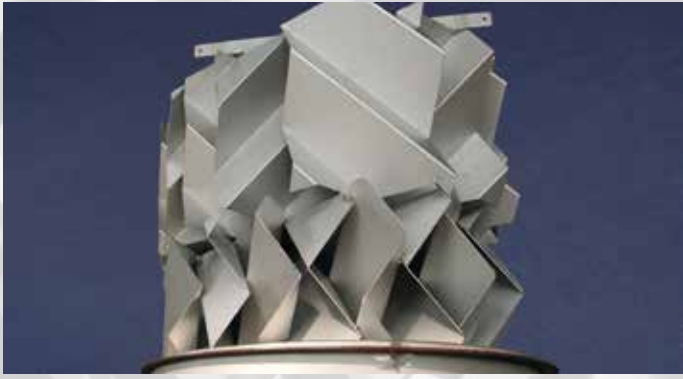

**Flue gas mixer for denitrification unit**



**GXM mixer for viscose chemical application**



**Ammonia mixer for power plant**



**Acid dilution mixer**



**Sodium hydroxide mixer**



**Application Examples:**

- Plastic Processing
- 2-Component Adhesives
- Mixing of various chemicals
- Mixing of flocculent agents in water
- Temperature mixing of flue gas
- Gasification of liquids with ozone or oxygen
- Mixing of blowing agents into Polyol for insulation sheets
- Mixing of ammonia gas into flue gas

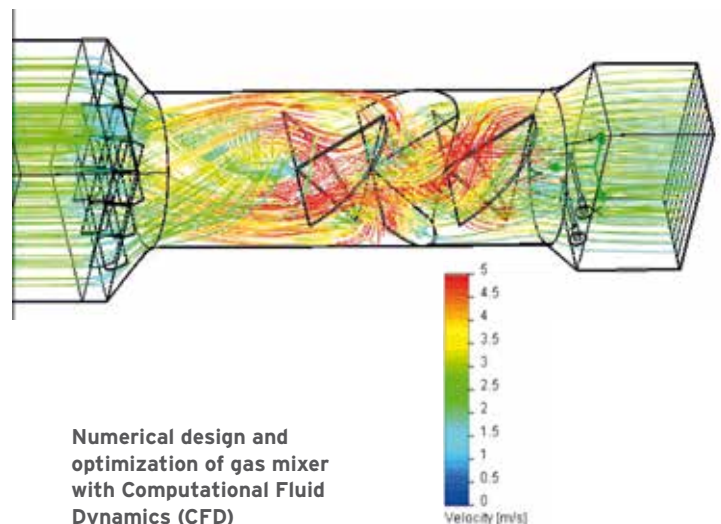

# Swiss-Made Quality



Static mixers, regardless of the field of application, are required to withstand the process operating conditions. We consistently rely on high quality for our products. At Stamixco, this begins with the proper choice of the static mixer design and raw materials and continues through on-going production checks that guarantee a consistent high quality product. Due to our comprehensive and thorough quality assurance program, we are able to offer reliable and durable static mixers - a fact confirmed again and again in discussions with long standing customers.

We always  
find a  
solution

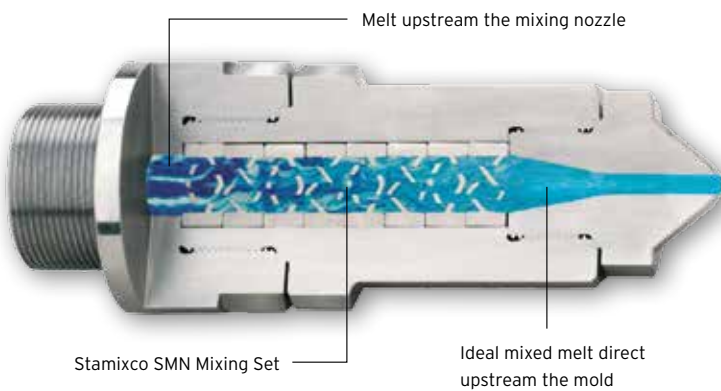
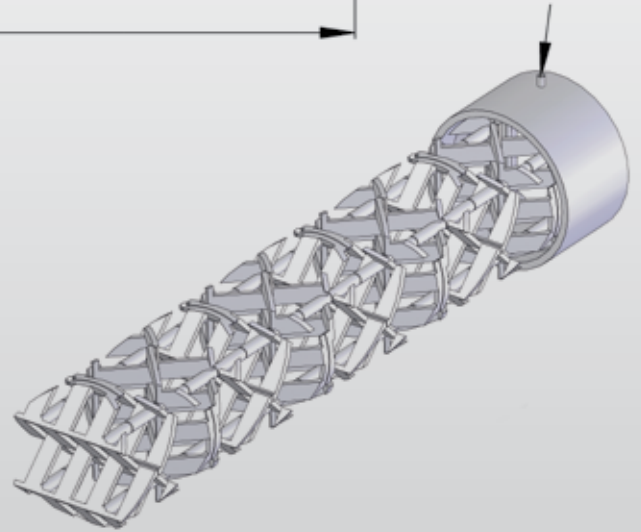
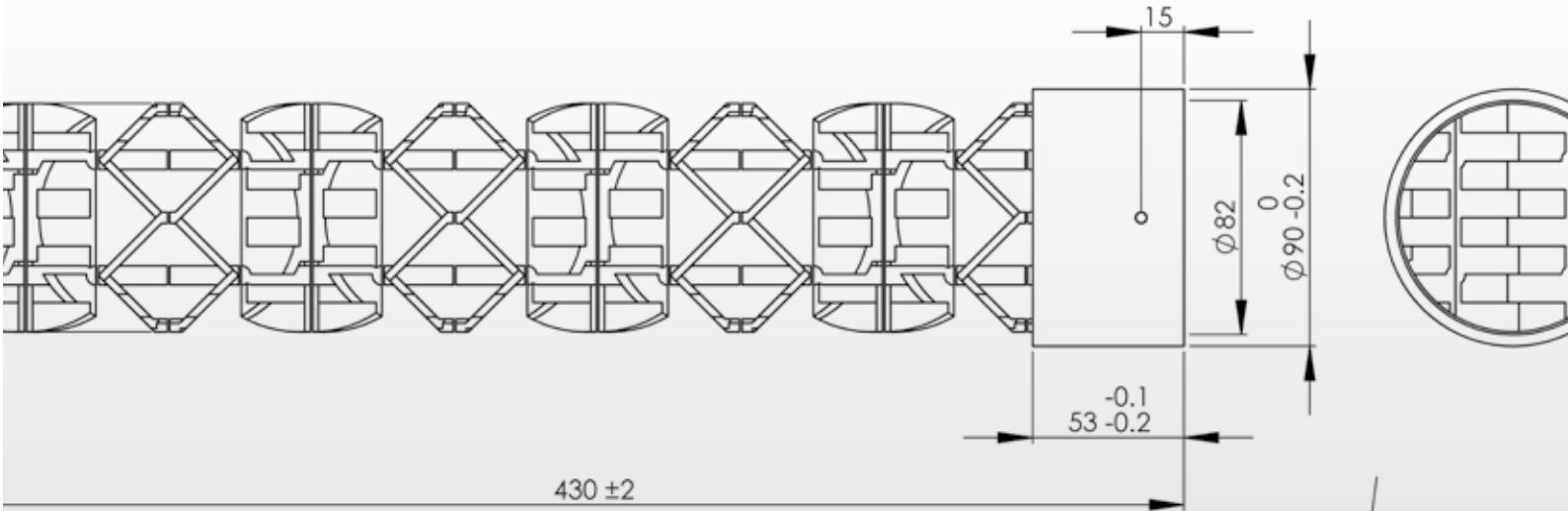

Our standard products cover the most frequent areas of application. We however continuously rely on consistent future developments to ensure that our customers can manufacture their products with increasing quality and efficiency. In some instances, standard products no longer suffice in solving a problem. Consult and ask us. We promise to apply our experience, skill and know-how in order to offer you the best solution.

„For us, good is not good enough“

# EUROPE

## Switzerland:

**Company Headquarters: Europe,  
Africa, Asia/Pacific**

### Stamixco Ltd. 1) 2) 3) 4)

Kronastrasse 10  
CH-8404 Winterthur, Switzerland

Tel.: +41 52 338 17 11  
Fax: +41 52 338 17 33  
E-mail: info@stamixco.com  
www.stamixco.com

### Benelux

Stamixco Ltd. 1) 2) 3) 4)  
Kronastrasse 10  
CH-8404 Winterthur, Switzerland

Tel.: +41 52 338 17 11  
Fax: +41 52 338 17 33

### Denmark

HH Plastkombi a/s 1) 2)  
Kildevej 162  
DK-3200 Helsinge

Tel.: +45 48 79 98 88  
Fax: +45 48 79 80 16  
E-Mail: mail@hh-plastkombi.dk  
www.hh-plastkombi.dk

### Germany

Nehlep & Schmidt GmbH 1)  
Volckmarstrasse 6  
DE-67547 Worms  
(Injection Molding)

Tel.: +49 6242 913 423-0  
Fax: +49 6242 913 423-99  
E-mail: info@nehlep-schmidt.eu  
www.nehlep-schmidt.de

BS Industrievertretungen 2)  
Herr Burkhard Schaab  
Klemmertstrasse 46  
DE-71088 Holzgerlingen  
(Extrusion)

Tel.: +49 7031 744 946  
Fax: +49 7031 604 965  
E-mail: info@bs-industrie.de  
www.bs-industrie.de

Schwing Verfahrenstechnik GmbH 4)  
Oderstrasse 7  
DE-47506 Neukirchen-Vluyn  
(General Mixing Technology)

Tel.: +49 2845 930-0  
Fax: +49 2845 930-100  
E-mail: mail@schwing-pmt.de  
www.schwing-pmt.de

### France

BMS France 1) 2)  
531, route de Vernes  
FR-74370 Pringy

Tel.: +33 450 272 900  
Fax: +33 450 273 822  
E-mail: info@bmsfrance.eu  
www.bmsfrance.eu

### Great Britain / Ireland

Invotec Solutions Ltd. 1) 2) 3)  
Unit 3, Stonebridge Eco.  
Deeping Gate, Stonebridge  
Milton Keynes MK13 ODE  
England

Tel.: +44 1908 322 282  
Fax: +44 1604 422 900  
E-mail: sales@invotecsolutions.co.uk  
www.invotecsolutions.co.uk

### Italy

OMNIA TECHNOLOGIES S.r.l. 1)  
Via Bonavia 10-14  
IT-40068 San Lazzaro Di Savena (BO)

Tel/Fax.: +39 0516270824  
E-mail: carlotta.bernardini@libero.it  
www.omniatechnologies.net

### Austria/Slowakia/Tszech Republic

PMK Kunststofftechnik Ges.b.R. 1) 2)  
Werfelstrasse 4/0/1  
AT-4614 Marchtrenk  
Austria

Tel.: +43 (0) 7243 51030  
Fax: +43 (0) 7243 51031  
E-mail: office@pmk-kunststofftechnik.at  
www.pmk-kunststofftechnik.at

### Poland

MUEHSAM - Elektromech 1) 2)  
Ul. Patriotów 341  
PL-04-760 Warszawa  
Poland

Tel.: +48 22 517 30 40  
Fax: +48 22 517 30 54  
E-mail: biuro@muehsam.com.pl  
www.muehsam.com.pl

### Portugal

SUTA FER REPRESENTAÇÕES LDA 1) 2)  
Rua António da Silva Tavares  
(Santeiro), no. 108  
PT-3721-257 Oliveira de Azeméis

Tel.: +351 256 660 690  
Fax: +351 256 660 699  
E-mail: sutafer@sutafer.com  
www.sutafer.com

### Spain

BUSINESS MOULDING SUPPLIES S.L.1) 2)  
Parque tecnologico ;  
c/Paletes No. 8, Edificio B  
ES-08290 Cerdanyola del Valles  
(Barcelona)

Tel.: +34 93 565 07 56  
Fax: +34 93 565 07 57  
E-mail: info@bmsespana.eu  
www.bmsespana.eu

Proximity to our customers is not merely a notion at Stamixco. Our corporate aim is to constantly assist you in solving your problems directly on-site on your premises. For this reason, we have established an international network of competent partners.

# Always close at hand



## **Israel**

Multipack Plastic L.T.D. 1) 2)  
P.O.B. 376  
IL-81103 Yavne

Tel.: +972 8 942 7325  
Fax: +972 8 942 0397  
E-mail: sales@multiplast.co.il

## **P. R. China**

CREATEX Engineering Co. Ltd. 1) 2)  
Shop B, G/F Wing Fat Bldg.  
No. 1 Chui Wo Lane  
Taipo, Hongkong N. T.  
P. R. China

Tel.: +852 2667 7393  
Fax: +852 2680 4181  
E-mail: createx@netvigator.com  
www.createxhk.com

## **Turkey**

ENFORMAK PT A.S. 1) 2)  
Beymersan Sa. Sit. 9, Cd. No. 14  
TR-34900 Beyliküzü  
ISTANBUL  
Turkey

Tel.: +90 212 879 03 14  
Fax: +90 212 879 03 13  
E-mail: enformak@enformak.com  
www.enformak.com

## **Hungary**

Mr. Dipl. Ing. György Ungvári 1) 2)  
Expert for Injection Molding  
Technology  
Hajcsár út 24  
HU-2225 Üllö  
Hungary

Tel.: +36 29 322 612  
Fax: +36 20 513 5636  
E-mail: gy.ungvari@monornet.hu

## **Latvia**

SIA ATEC Engineering 1) 2)  
ŠampĢtera iela 2  
LV-1046 Riga  
Latvia

Contact: Alex Kochnev  
Tel.: +371 6780 4870  
Mobile: +371 2233 4168  
E-mail: alexkochnev@atecplastics.com  
www.atecplastics.com

## **Singapore/Malaysia/Thailand/ Indonesia**

TS INDUSTRIAL SERVICES Pte Ltd 1) 2)  
48, Toh Guan Road East  
No. 07-105 Enterprise Hub  
Singapore 608605

## **Singapore, Indonesia:**

Tel.: +65 6569 6848 /  
+65 9689 78 56  
Fax: +65 6569 0468

## **Thailand:**

Tel.: +66 7818 4717

## **Malaysia:**

Tel.: +607 3515 600 /  
+60 123 087 123  
Fax: +607 3525 600

E-mail : ysloh@triplas.com  
www.triplas.com

## **Distribution categories:**

- 1) Injection Molding Mixing Nozzles & Filters
- 2) Extrusion Melt Blenders
- 3) Plastic Disposable Static Mixers
- 4) General Mixing

## **ASIA/PACIFIC**

### **India 1) 2)**

Madhu Machines & Systems Pvt. Ltd.  
A-4/5, „Anurag”, Ganesh Krupa  
Soc.  
Chikuwadi  
IN-390007 Vadodara  
India

Tel.: +91 265 235 3886  
Fax: +91 265 233 4278  
E-mail: machinery@madhu-group.com  
www.madhu-group.com

## **AMERICAS**

### **USA/Canada/Mexiko/ South America**

associated company

Stamixco LLC 1) 2) 3)  
235 - 84th Street  
Brooklyn, NY 11209  
USA

Tel.: +1 718 748 4600  
Fax: +1 718 833 8827  
E-mail: stamixco@msn.com  
www.stamixco-usa.com

# stamixco

Mix it up ...



**Static Mixers  
for Injection Molding**

**Static Mixers  
for Extrusion**

**Plastic Disposable Mixers**

**General Mixing  
Technology**

**Stamixco Ltd.**

Kronastrasse 10  
CH-8404 Winterthur  
Switzerland

Phone: +41 (0)52 338 17 11  
Fax: +41 (0)52 338 17 33  
[www.stamixco.com](http://www.stamixco.com)  
[info@stamixco.com](mailto:info@stamixco.com)

